



55
kN



FORGED STEEL IN
MY BODY



7
kg

Swing damper or link with brakes FHL 05B is designed to withstand loads up to 5.5t. Link FHL 05B is made from shock and deformation resistant forged steel. Links with brakes are useful in situations where smoothen the cargo swinging is required

Swing damper FHL 05B upper interface is performed in knuckle joint eye form factor and compatible with fork shape crane tip.

Link designed width optional upper interface size. Available models for crane tip fork ends 60mm, 70mm, 80mm, . Available models for upper interface pin diameters 25mm, 30mm, 35mm, 40mm, 45mm, .



Formiko swing damper FHL 05B is compatible with fork shape upper interface rotators. Various models for rotator upper interface widths 60mm, 73mm, rotator and link connecting pin diameter options: 25mm, 30mm,

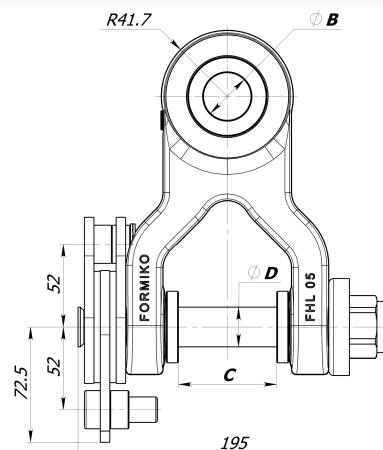
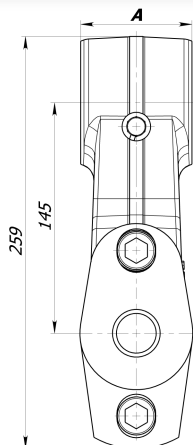

LINK FHL 05B MOUNTING SIZE OPTIONS

A Upper interface width	B Upper interface pin Ø	C Rotator interface width	D Lower interface pin Ø
60mm	25mm	60mm	25mm
70mm	30mm	73mm	30mm
80mm	35mm		
	40mm		
	45mm		

exact.link.name **FHL 05B-A/B -C/D**

For additional information relating to price levels and technical data, please contact sales@formiko.lv

Formiko Hydraulics Ltd

Dzirčiema Str. 119 k-1,
Rīga LV1055 LATVIA

+371 294 49 552

+371 264 59 383

sales@formiko.lv

www.formiko.lv



FORESTRY



GENERAL CARGO



AGRICULTURE



CONSTRUCTION



RECYCLING

