



160
kN

-130
kN

80
kN

-65
kN

3400
nm

79
kg

40
l/min



DOUBLE
ROLLER/TAPPER
BEARING



L103.2
ø50.8
mm



1/2"
BSP



250
bar



1/2"
BSP



300
bar



300
bar

Hydraulic rotator FHR 16FD1-A8H designed for heavy duty machinery to meet the highest demands for quality and reliability. Ideal for intensive professional use in forestry, agriculture, road and building construction, recycling industry, general cargo and material handling.



Rotator's upper mount is applied in FORK form factor of the knuckle joint. Robust and tough built to withstand even overloads. The fork width (between fork ends) is common standard width 103.2mm and the knuckle pin diameter 50.8mm.

Rotator lower mount is applied in FLANGE form factor to mount direct on grapple / tool surface by fixing with screws



ø204
17(x8)
mm



1/2"
BSP



1/2"
BSP

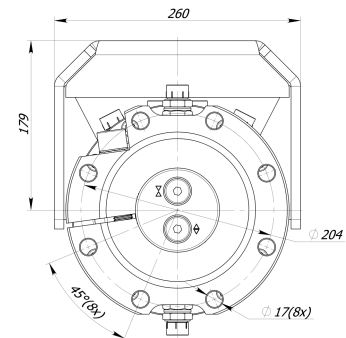
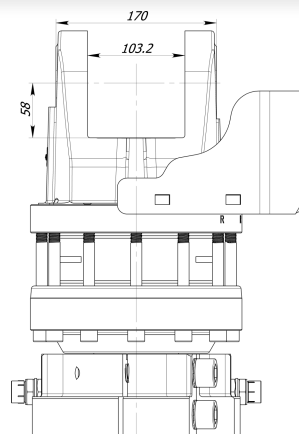
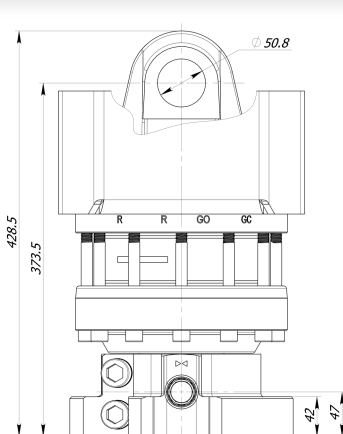

For additional information relating to price levels and technical data, please contact sales@formiko.lv

Formiko Hydraulics Ltd

Dzirciema Str. 119 k-1,
Rīga LV1055 LATVIA

+371 294 49 552
+371 264 59 383
sales@formiko.lv
www.formiko.lv

On request by special conditions there are metric nipples available for rotator FHR 16FD1-A8H



FORESTRY



GENERAL CARGO



AGRICULTURE



CONSTRUCTION



RECYCLING





Hydraulic rotator FHR 16FD1-A8H designed for heavy duty machinery to meet the highest demands for quality and reliability. Ideal for intensive professional use in forestry, agriculture, road and building construction, recycling industry, general cargo and material handling.



Rotator's upper mount is applied in FORK form factor of the knuckle joint. Robust and tough built to withstand even overloads. The fork width (between fork ends) is common standard width 103.2mm and the knuckle pin diameter 50.8mm.



Rotator lower mount is applied in FLANGE form factor to mount direct on grapple / tool surface by fixing with screws



Rotator FHR 16FD1-A8H based on reliable vane type hydraulic motor which delivers torque up to 3400Nm at 25MPa.



Formiko Hydraulics rotator FHR 16FD1-A8H is equipped with double bearings to withstand both tensional and pushing loads.



Rotator for shipping is packed in compact solid cardboard box with dimensions 450x250x250mm.



We providing TWO year warranty for this rotator.

For additional information relating to price levels and technical data, please contact sales@formiko.lv

Formiko Hydraulics Ltd

Dzirclēma Str. 119 k-1,
Rīga LV1055 LATVIA

+371 294 49 552
+371 264 59 383
sales@formiko.lv
www.formiko.lv

On request by special conditions there are metric nipples
available for rotator FHR 16FD1-A8H

FORESTRY



GENERAL CARGO



AGRICULTURE



CONSTRUCTION



RECYCLING

