



**30**  
kN



**15**  
kN

**900**  
nm

**22**  
kg

**20**  
l/min



FHL 01-A/B-60/25



FHL 01B-A/B-60/25



FHL 05B-A/B-60/25



FHL 05-A/B-60/25



FHL 04-2525

160 $\phi$ 25 mm	3/8" BSP	250 bar	3/8" BSP	200 bar	300 bar

Hydraulic rotator FHR 3RF-01 is cost-effective solution generally for seasonal use in forestry, agriculture, road and building construction, general cargo and material handling.

Rotator's upper mount is applied in EYE form factor of the knuckle joint. Robust and tough built to withstand even overloads. The wide of eye is common standard width 60mm and the knuckle pin diameter 25mm.



Rotator lower mount is applied in FLANGE form factor to mount direct on grapple / tool surface by fixing with screws

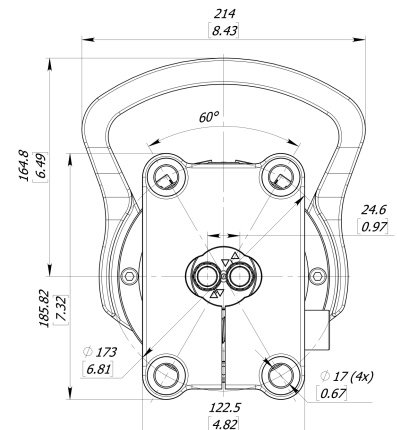
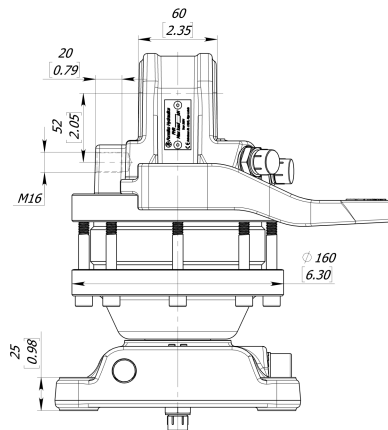
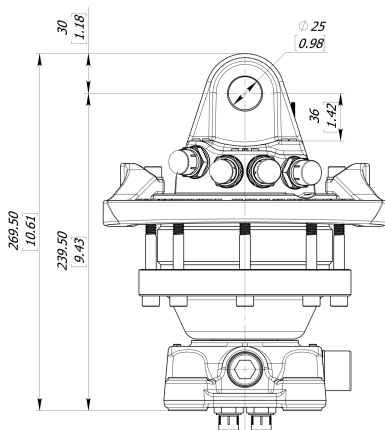

For additional information relating to price levels and technical data, please contact sales@formiko.lv

Formiko Hydraulics Ltd  
Dzirciema Str. 119 k-1,  
Riga LV1055 LATVIA

+371 294 49 552  
+371 264 59 383  
sales@formiko.lv  
www.formiko.lv

On request by special conditions there are metric nipples available for rotator FHR 3RF-01



FORESTRY



AGRICULTURE



CONSTRUCTION





Hydraulic rotator FHR 3RF-01 is cost-effective solution generally for seasonal use in forestry, agriculture, road and building construction, general cargo and material handling.



Rotator's upper mount is applied in EYE form factor of the knuckle joint. Robust and tough built to withstand even overloads. The wide of eye is common standard width 60mm and the knuckle pin diameter 25mm.



Rotator lower mount is applied in FLANGE form factor to mount direct on grapple / tool surface by fixing with screws



Rotator FHR 3RF-01 based on reliable vane type hydraulic motor which delivers torque up to 900Nm at 25MPa.



Some parts in rotator are built from shock resistant and deformation resistant forged steel.



Formoko rotator FHR 3RF-01 is compatible with FHL 01-A/B-60/25 and FHL 01B-A/B-60/25 and FHL 05B-A/B-60/25 and FHL 05-A/B-60/25 and FHL 04-2525 series links.



Rotator for shipping is packed in compact solid cardboard box with dimensions 340x230x240mm.



Lower connection from under.



We providing TWO year warranty for this rotator.

For additional information relating to price levels and technical data, please contact [sales@formiko.lv](mailto:sales@formiko.lv)

**Formiko Hydraulics Ltd**

Dzirciema Str. 119 k-1,  
Riga LV1055 LATVIA

+371 294 49 552

+371 264 59 383

[sales@formiko.lv](mailto:sales@formiko.lv)

[www.formiko.lv](http://www.formiko.lv)

On request by special conditions there are metric nipples  
available for rotator FHR 3RF-01



FORESTRY



AGRICULTURE



CONSTRUCTION

